

# Sliding Motor



**It's DP  
It's Develop**

# Horse

## Introduction

DP is producing the sliding door motor mainly from 300kgs to 2400kgs with Series of "Mouse", "Horse" and "Dog". The motors are powerful and safe. starts smoothly, with bigger torque, and lower noise, and they are smooth and reliable when operating, so they are favored by most customers from all over the world.



# Horse 300/600KG

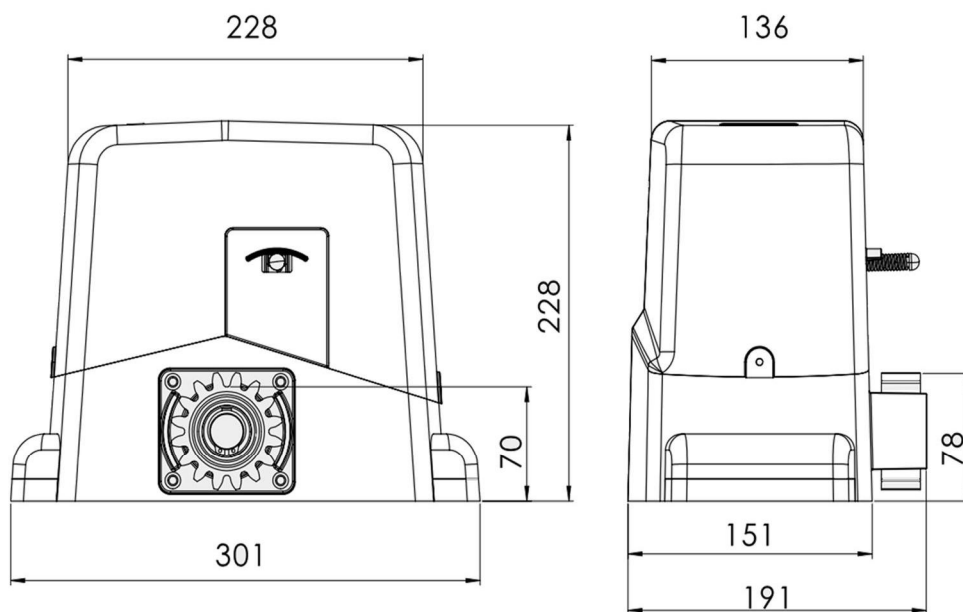

Item No	Horse 300KG	Horse 600KG
Power Supply	AC220V/AC110V	AC220V/AC110V
Torque	7N.M	10N.M
Motor Speed	1440RPM	1440RPM
Gate Speed	10m/min	10m/min
Max Gate Weight	300Kg	600Kg
Noise	≤56dB	≤56dB
Limited switch	Magnetic/Mechanical (N.O. / N.C.)	Magnetic/Mechanical (N.O. / N.C.)
Thermal Protection Temperature	135°C	135°C
Working Cycle	25%	25%
Working Temperature	-45°C~+65°C	-45°C~+65°C
IP Class	IP44	IP44
Certificates	ROHS, CE	ROHS, CE

# Horse 800/1000KG

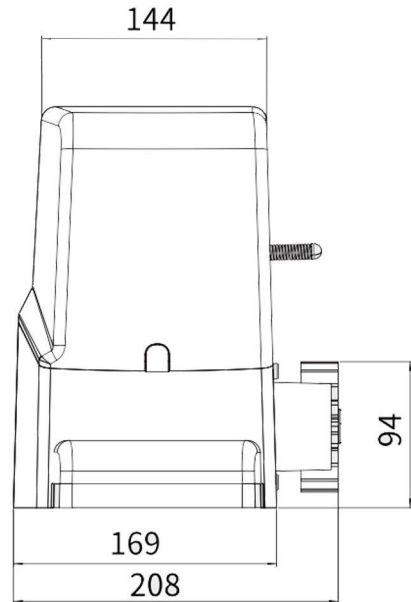
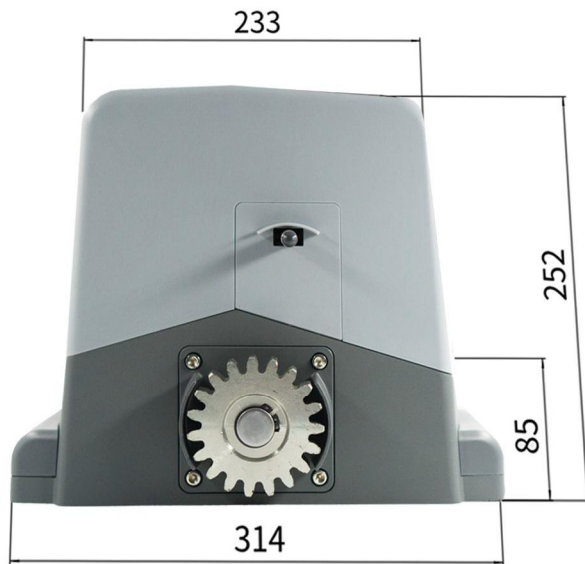

Item No	Horse 800KG	Horse 1000KG
Power Supply	AC220V/AC110V	AC220V/AC110V
Torque	22N.M	27N.M
Motor Speed	1440RPM	1440RPM
Gate Speed	12m/min	12m/min
Max Gate Weight	800Kg	1000Kg
Noise	≤56dB	≤56dB
Limited switch	Magnetic/Mechanical (N.O. / N.C.)	Magnetic/Mechanical (N.O. / N.C.)
Thermal Protection Temperature	135°C	135°C
Working Cycle	40%	40%
Working Temperature	-45°C~+65°C	-45°C~+65°C
IP Class	IP44	IP44
Certificates	ROHS, CE	ROHS, CE



# Mouse

**Mouse**

**800KG-2400KG**

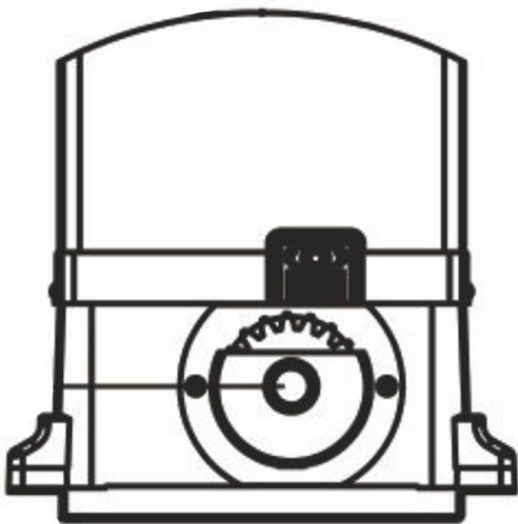

# Mouse 800-2400KG

1. Motor power
2. Power supply
3. Motor rotational speed
4. Out rotational speed
5. Working temperature
6. Thermal protection temperature
7. Max weight of gate
8. Limit

## MOUSE370

1. 370W
2. AC220V / 50Hz  
AC110V/60Hz.
3. 1400R/min
4. 46R /min
5. -30 to 60°C.
6. Temperature is 110°C.
7. 800KGS
8. Spring/Magnetic

## MOUSE550

1. 550W
2. AC220V / 50Hz  
AC110V/60Hz.
3. 1400R/min
4. 46R /min
5. -30 to 60°C.
6. Temperature is 110°C.
7. 1200KGS
8. Spring/Magnetic

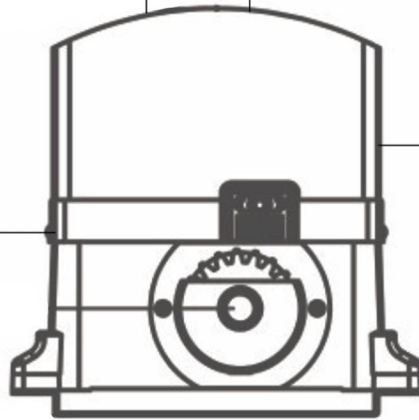

## MOUSE750

1. 750W
2. AC220V / 50Hz  
AC110V/60Hz.
3. 1400R/min
4. 46R /min
5. -30 to 60°C.
6. Temperature is 110°C.
7. 1600KGS
8. Spring/Magnetic

## MOUSE950-1200

1. 950-1200W
2. AC220V / 50Hz  
AC110V/60Hz.
3. 1400R/min
4. 46R /min
5. -30 to 60°C.
6. Temperature is 110°C.
7. 2000-2400KGS
8. Spring/Magnetic

# Dog

## 600KG-2000KG

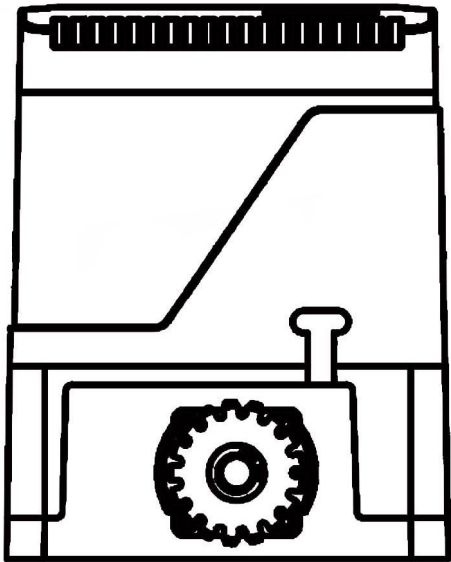

# Dog



# Slide W600AC/W800AC

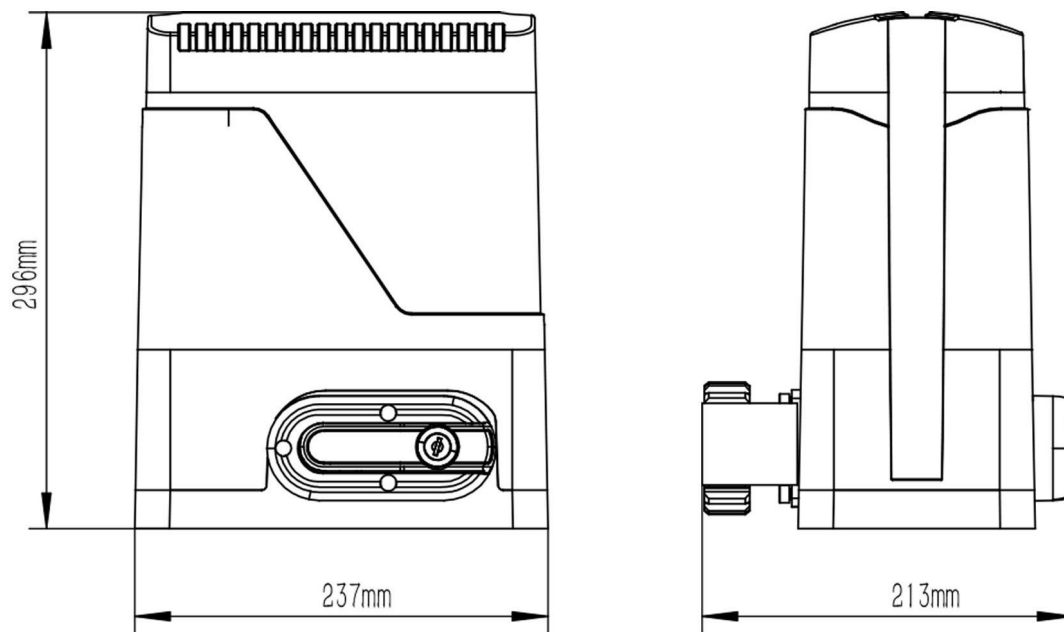

Item No	Slide W600AC	Slide W800AC
Power Supply	220V/50Hz;110V/60Hz	220V/50Hz;110V/60Hz
Motor Power	280W	380W
Working Temperature	-20°C~+70° C	-20°C~+70° C
Gate Speed	13m/min	13m/min
Max Gate Weight	500Kg	800Kg
Noise	≤56dB	≤56dB
Limited switch	Magnetic/Mechanical (N.O. / N C.)	Magnetic/Mechanical (N.O. / N C.)
Working Duty	S2, 20min	S2, 20min
Remote control distance	≥30m	≥30m
Remote control mode	Single button mode/ Three button mode	Single button mode/ Three button mode
Frequency	433.92 MHz	433.92 MHz
Package weight	10.10Kg	10.18Kg



# Slide W1000AC/W1500AC/W2000AC

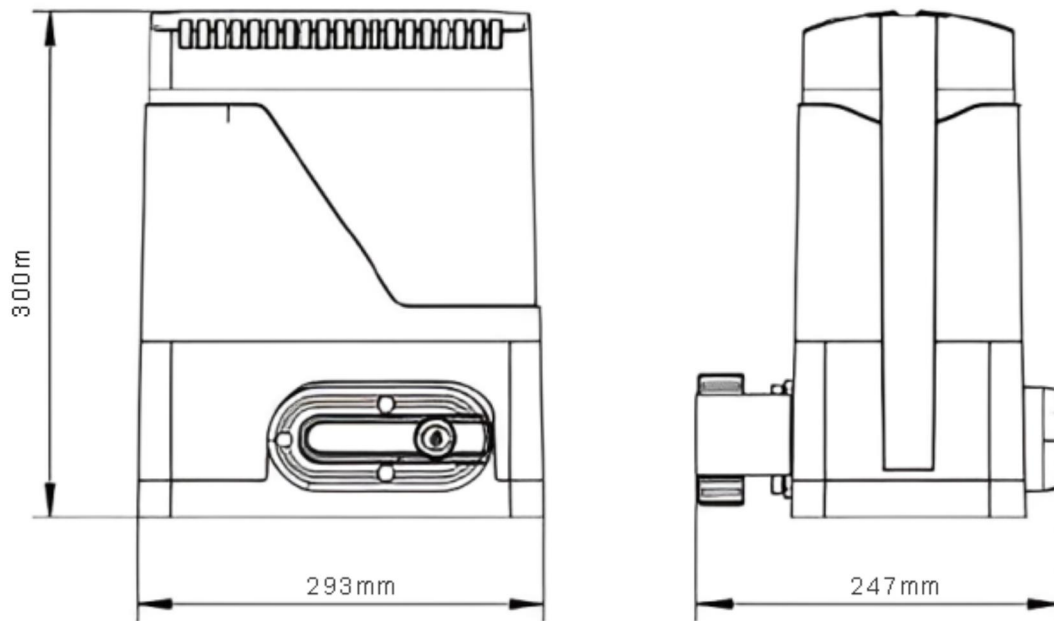

Item No.	Slide W1000AC	Slide W1500AC	Slide W2000AC
Power Supply	110VAC/60Hz,220VAC/50Hz		
Motor power	400W	550W	750W
Working Temperature	-20℃~+70℃		
Gate speed	12m/min	12m/min	12m/min
Max Gate Weight	1000kg	1500kg	2000kg
Noise	≤56dB	≤56dB	≤56dB
Limit switch	Spring limit switch/Magnetic limit switch		
Working Duty	S2, 20min		
Rempte control distance	≥30m		
Remote control mode	Single button mode / Three button mode		
Frequency	433.92MHz		
Package Weight	14.5KGS	14.9KGS	16.5KGS

# Slide W600DC/W800DC

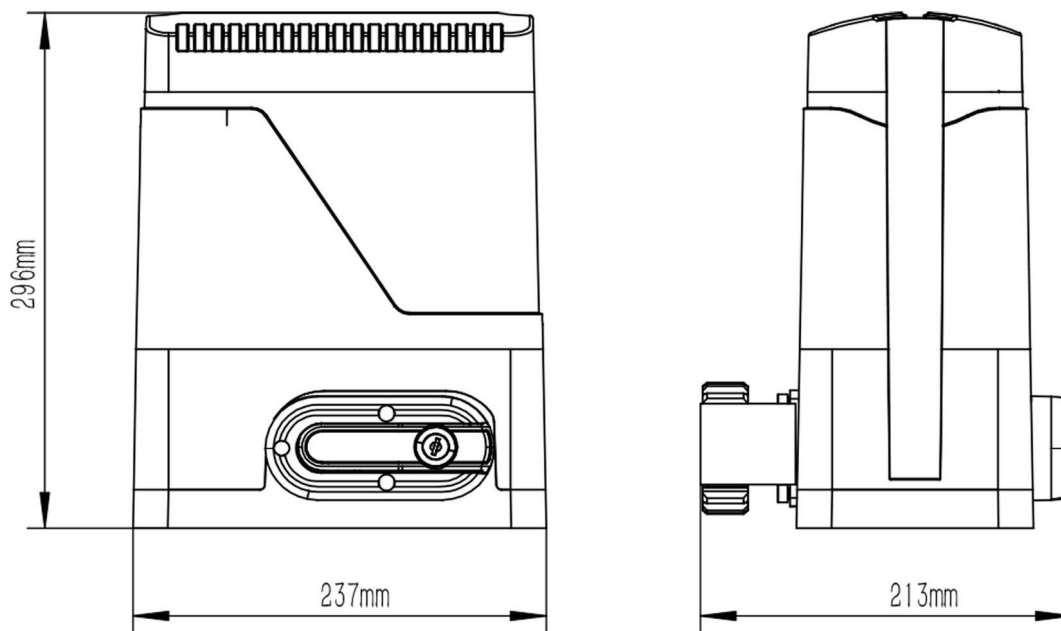

Item No	Slide W600DC	Slide W800DC
Power Supply	220V/50Hz;110V/60Hz	220V/50Hz;110V/60Hz
Motor Power	150W	170W
Working Temperature	-20°C~+70° C	-20°C~+70° C
Gate Speed	13m/min	18m/min
Max Gate Weight	500Kg	800Kg
Noise	≤58dB	≤58dB
Limited switch	Magnetic/Mechanical (N.O. / N C.)	Magnetic/Mechanical (N.O. / N C.)
Working Duty	S2, 20min	S2, 20min
Rempte control distance	≥30m	≥30m
Remote control mode	Single button mode/ Three button mode	Single button mode/ Three button mode
Frequency	433.92 MHz	433.92 MHz
Package weight	10Kg	11Kg

# Slide W1000DC

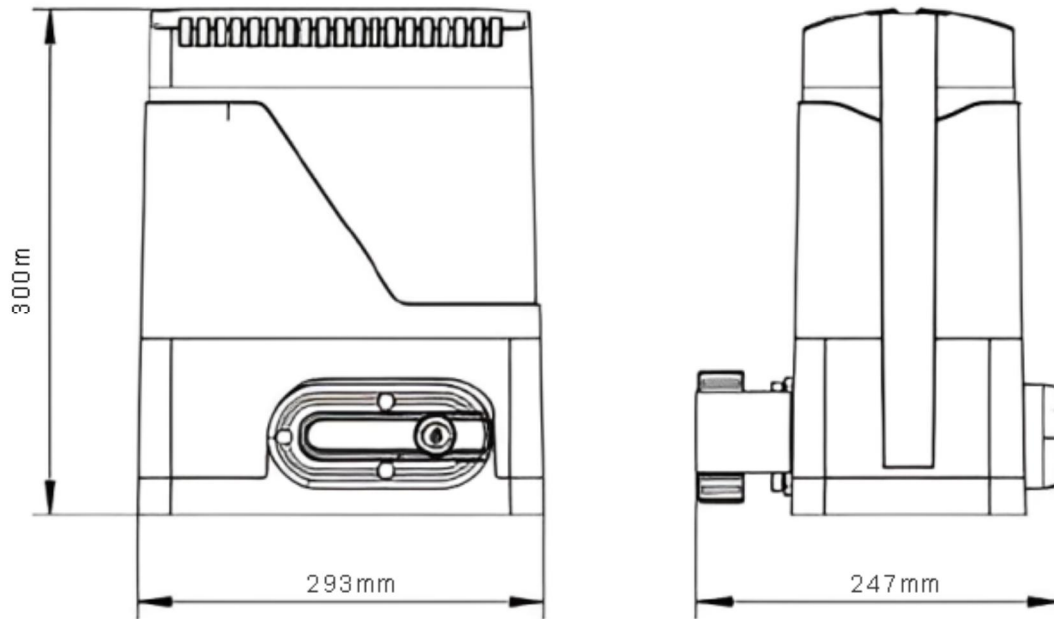

Item No.	Slide W1000DC
Power Supply	110VAC/60Hz,220VAC/50Hz
Motor power	250W
Working Temperature	-20 C-+70 C
Gate speed	24m/min
Max Gate Weight	1000kg
Noise	≤56dB
Limited switch	Spring limit switch / Magnetic limit switch
Working Duty	S2, 20min
Rempte control distance	≥30m
Remote control mode	Single button mode / Three button mode
Frequency	433.92MHz
Package Weight	13KGS

**Pig**  
**3000-6000KG**

**Pig**





# PIG 3000/3500KG

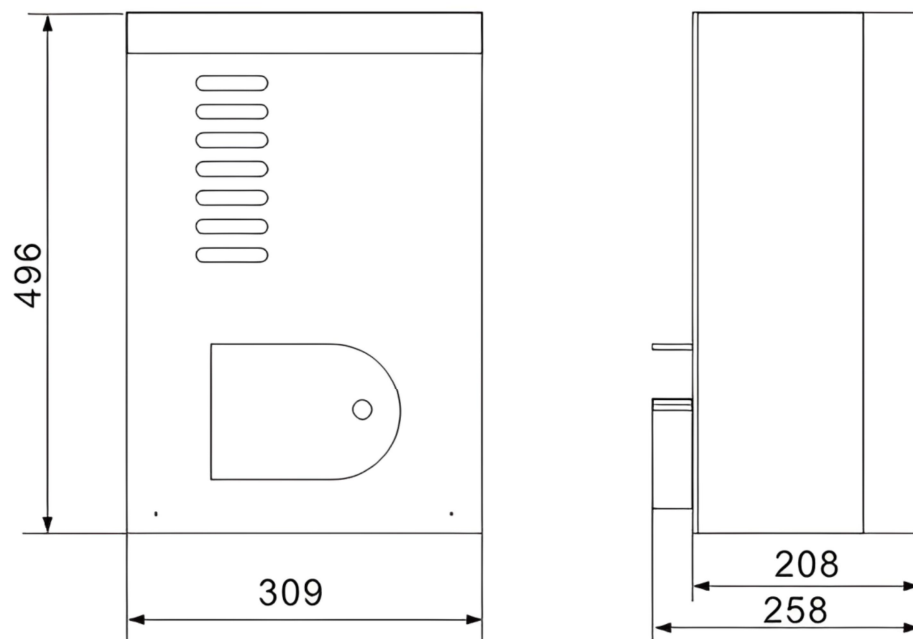

Item No.	PIG3000	PIG3500
Input Voltage	220V/50Hz	380V/50Hz
Motor power	1000W	1000W
Temperature	-45℃ ~ +65℃	-45℃ ~ +65℃
Gate speed	11m/min	11m/min
Max gate weight	3000kg	3500kg
Noise	≤58dB	≤58dB
Limit switch	Spring/Magnetic (N.O./NC.)	Spring/Magnetic (N.O./NC.)
Motor speed	1400r/min	1400r/min
Gear teeth	23T	23T
Output torque	170N.m	180N.m

# PIG 4000/6000KG

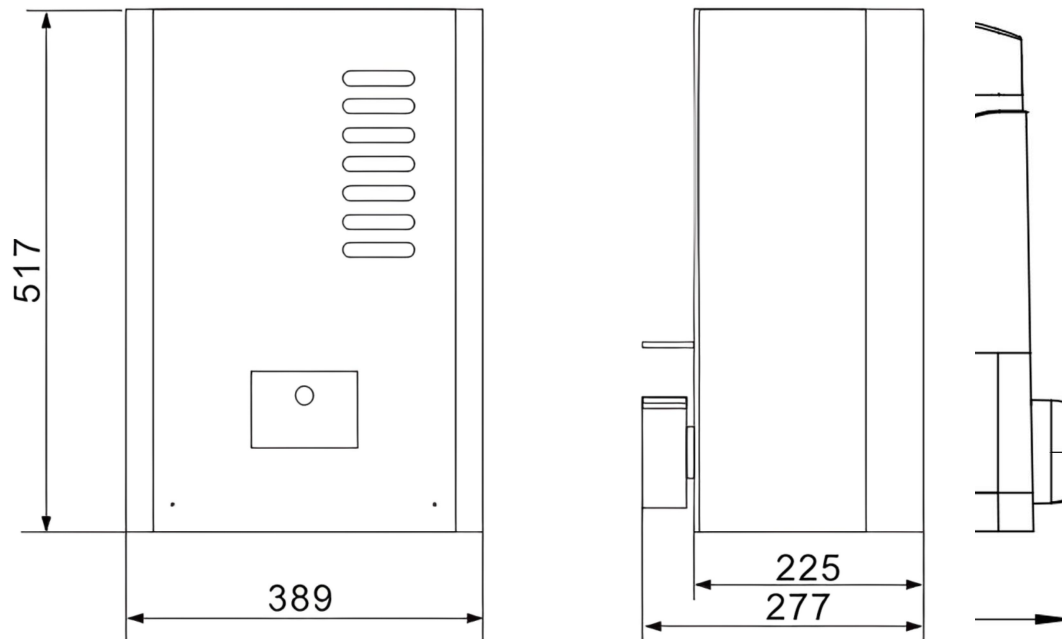

Item No.	PIG4000	PIG6000
Input Voltage	380V/50Hz	380V/50Hz
Motor power	1500W	2200W
Temperature	-45℃~+65℃	-45℃~+65℃
Gate speed	12m/min	12m/min
Max gate weight	4000kg	6000kg
Noise	≤58dB	≤58dB
Limit switch	Spring/Magnetic (N.O./NC.)	Spring/Magnetic (N.O./NC.)
Motor speed	1400r/min	1400r/min
Gear teeth	23T	23T
Output torque	220N.m	280N.m