

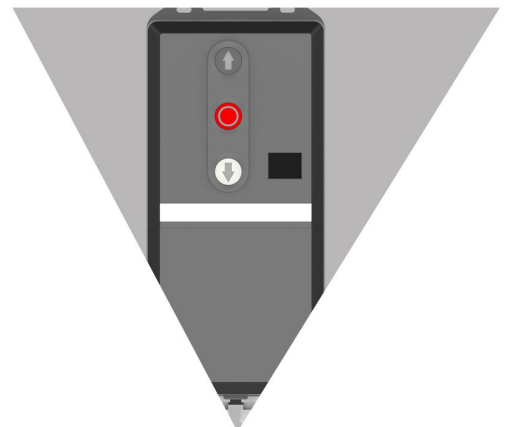

INDUSTRIAL DOOR MOTOR

N:16016



LION



DC series

Automation for Industrial Doors

LION 35



APPLICATION:

- > Residential Double Garage Door
- > Commercial Logistics & Parking Lot Doors
- > Factory Entrance Industrial Doors

DOOR SIZE SUPPORTED:

- Upto 195 Kgs Door Weight Supported
- Upto 15 m Door Size Supported
- Upto 5.0m Door High Supported

DOOR TYPE SUPPORTED:

- Sectional Panel Garage Door
- Sandwich/ Alu Panorama or Commercial Doors

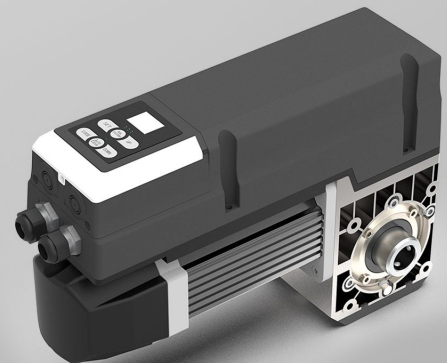

.CIRCULATION CLUTCH

- PLUGGABLE CLUTCH
- CONVENIENT FOR MANUALLY OPENING
- PATENTED DESIGN



.DC DRIVE

- SAFETY ENSURANCE
- SOFT START & SOFT STOP
- SILENTLY RUNNING
- AUTOMATICALLY OBSTACLE REVERSE



.AUTO ADJUSTED FORCE SYSTEM (AAFS)

- SMART CALCULATION SYSTEM
- EASIEST INSTALLATION
- AUTO SELECTED FORCE SYSTEM
- THE BEST POINT OF POWER, SMOOTHNESS AND SILENCE
- AUTO-LEARNING SYSTEM FOR EVERY RUNNING

PARAMETER . LION 35

Maximum Output torque	35Nm	1 Gearbox
Rated output torque	25Nm	2 Motor
Input voltage	110/220(1+10%)V 50Hz	3 Casing
Control system	24V DC	4 Flip
Motor power	0.35 Kw	5 Rear trim cover
Static holding torque	400Nm	6 Front clutch
Max. output speed	24rpm-32rpm	
Operation limit turns (limit travel)	15 turns of output shaft (max. 5.0m lifting height recommend)	
Sleeve shaft diameter (standard)	φ25.4mm	
Keyway size	6.3mm	
Thermal protection temperature	105°C	
Continuous sound pressure level	<70dB	
Max. cycles per hour	20	
IP protection class	IP54	
Temperature range	- 20°C /+ 60°C	
Standard kit	Drive motor&push button or TX/RX control	
Quick release with rope	Including	
Chain hoist module	Optional	
Optional sensing edge set (TX and RX)	Optional	No active closing edge protection necessary for doors up to 14m ² Soft-Start and Soft-Stop protect the door and reduce repair costs

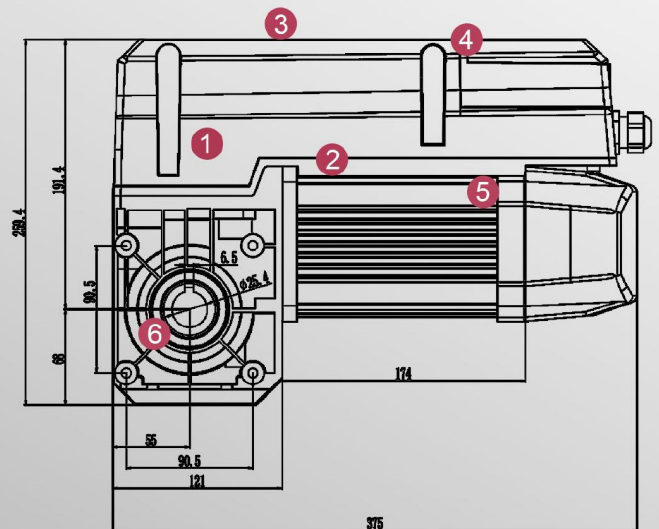

Standard sectional doors with cylindrical cable drum

	Door size(max.)	18m ²	Door weight(max.)	234kg
---	-----------------	------------------	-------------------	-------

Vertical lift sectional doors with conical cable drum

	Door size(max.)	14m ²	Door weight(max.)	182kg
---	-----------------	------------------	-------------------	-------

High lift sectional doors with cylindrical-conical cable drum

	Door size(max.)	18m ²	Door weight(max.)	234kg
---	-----------------	------------------	-------------------	-------

LION 50

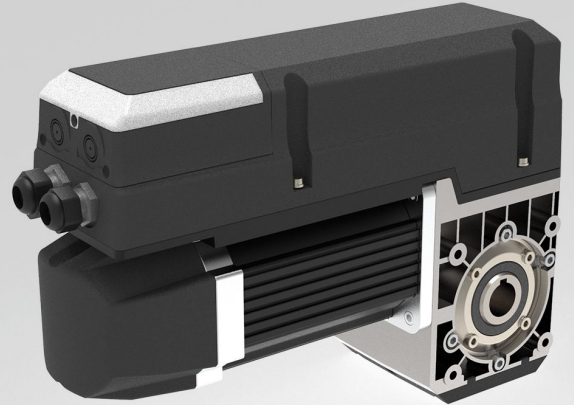

.AUTO ADJUSTED FORCE SYSTEM (AAFS)



.DC DRIVE



.CIRCULATION CLUTCH

APPLICATION

- FACTORY/ WAREHOUSE INDUSTRIAL DOORS
- LOGISTICS CENTER DOORS
- COMMERCIAL CENTER/ PARKING LOT DOORS

DOOR TYPE SUPPORTED

- SANDWICH INSULATED GARAGE/INDUSTRIAL DOORS
- ALU PANORAMA OR COMMERCIAL INDUSTRIAL DOORS

DOOR SIZE SUPPORTED



- UPTO 18 M² DOOR SIZE SUPPORTED
- UPTO 234 KGS DOOR WEIGHT SUPPORTED
- UPTO 7.0M DOOR HIGH SUPPORTED

PARAMETER LION 50

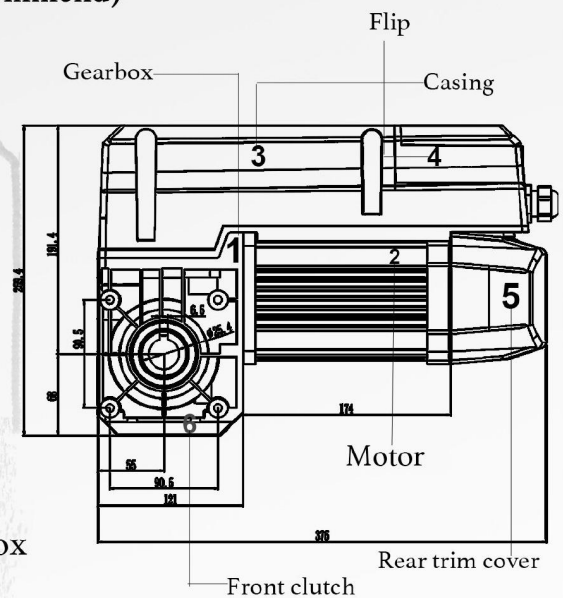
● MAXIMUM OUTPUT TORQUE	50Nm
● Rated out torque	35Nm
● Input voltage	110/220(1+10%)V 60Hz/50Hz 380V-420V
● Control system	24V DC
● Motor power	0.45Kw
● Static holding torque	400Nm
● Max. output speed	24rpm-32rpm
● Operation limit turns (limit travel)	15 turns of output shaft (max. 6.5m lifting height recommend)
● Sleeve shaft diameter (standard)	φ25.4mm
● Keyway size	6.3mm
● Thermal protection temperature	105°C
● Continuous sound pressure level	< 70dB
● Max. cycles per hour	20
● IP protection class	IP54
● Temperature range	- 20°C /+ 60°C
● Standard kit	Drive motor&wired control box
● Quick release with rope	Including
● Chain hoist module	Optional
● Optional sensing edge set (TX and RX)	Optional



No active closing edge protection necessary for doors up to 14m²
Soft-Start and Soft-Stop protect the door and reduce repair costs

Standard sectional doors with cylindrical cable drum				
Door size(max.)	22m ²	Door weight(max.)	286 Kg	
Vertical lift sectional doors with conical cable drum				
Door size(max.)	18m ²	Door weight(max.)	234Kg	
High lift sectional doors with cylindrical-conical cable drum				
Door size(max.)	22m ²	Door weight(max.)	286Kg	

LION 70



APPLICATION

- Factory Industrial Doors
- Factory Industrial Doors
- Commercial Entrance Doors

Door Size Supported

- Upto 25 m2 Door Size Supported
- Upto 325 Kgs Door Weight Supported
- Upto 9. 0m Door High Supported

Door Type Supported

- Sandwich Insulated Garage/ Industrial Doors
- Alu Panoramaor CommercialIndustrial Doors



.AUTO ADJUSTED FORCE SYSTEM (AAFS)

- SMART CALCULATION SYSTEM
- EASIEST INSTALLATION
- AUTO SELECTED FORCE SYSTEM
- THE BEST POINT OF POWER, SMOOTHNESS AND SILENCE
- AUTO-LEARNING SYSTEM FOR EVERY RUNNING



.DC DRIVE

- SAFETY ENSURANCE
- SOFT START&SOFT STOP
- SILENTLY RUNNING
- AUTOMATICALLY OBSTACLE REVETRSE



.CERCULATION CLUTCH

- PLUGGABLE CLUTCH
- CONVENIENT FOR MANUALLY OPENING
- PATENTED DESIGN

PARAMETER. LION 70

- 1 Gearbox
- 2 Motor
- 3 Casing
- 4 Flip
- 5 Rear trim cover
- 6 Front clutch

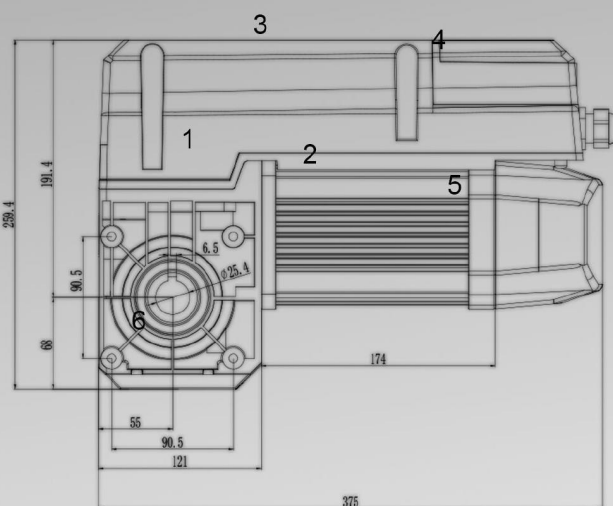

Maximum Output torque	70Nm
Fated output torque	50Nm
Input voltage	110/220(1+10%)V 60HZ/50Hz 380v-420V
Control system	24V DC
Motor power	0.55Kw
Static holding torque	400Nm
Max. output speed	24rpm-32rpm
Operation limit turns (limit travel)	15 turns of output shaft (max. 8.0m lifting height recommend)
Sleeve shaft diameter (standard)	φ25.4mm
Keyway size	6.3mm
Thermal protection temperature	105°C
Continuous sound pressure level	<70dB
Max. cycles per hour	20
IP protection class	IP54
Temperature range	- 20°C /+ 60°C
Standard kit	Drive motor&wired control box
Chain hoist module	Including
Optional sensing edge set (TX and RX)	Optional

No active closing edge protection necessary for doors up to 14m²
Soft-Start and Soft-Stop protect the door and reduce repair costs

Standard sectional doors with cylindrical cable drum

Door size(max.) **28m²** Door weight(max.) **364kg** 

Vertical lift sectional doors with conical cable drum

Door size(max.) **24m²** Door weight(max.) **312kg** 

High lift sectional doors with cylindrical-conical cable drum

Door size(max.) **28m²** Door weight(max.) **364kg** 

THE CONTROL IS SUITABLE FOR
50N. M AND 70N.M
INDUSTRIAL DOOR OPENER.

THE INTERNAL INTERFACE HAS
CLEAR INSTRUCTIONS,
SO THAT YOU WILL NOT HAVE ERRORS
WHEN WIRING
FUNCTION SHORTCUT KEY,EASY TO OPERATE

BIG BUTTONS

- O.S. C THREE BUTTONS
- SILICONE BUTTON, MORE SKID PROOF
- BIG KEYS, NOT EASY TO PRESS WRONG

SHORTCUT KEYS

- PRESS TO LEARN CODE, MORE CONVENIEN
- SILICONE BUTTON, MORE SKID PROOF
- CLEAR INSTRUCTIONS NOT EASY TO MAKE MISTAKES

LED LIGHTS

- INNOVATIVE DESIGN, MORE BEAUTIFUL
- IN THE DARK, THE SIGHT IS STILL CLEAR

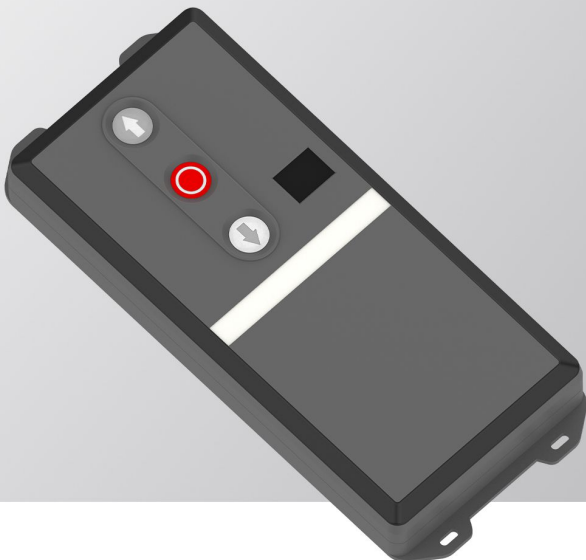

CONTROL BOX

BEAR



AC series

Automation for Industrial Doors

BEAR 120

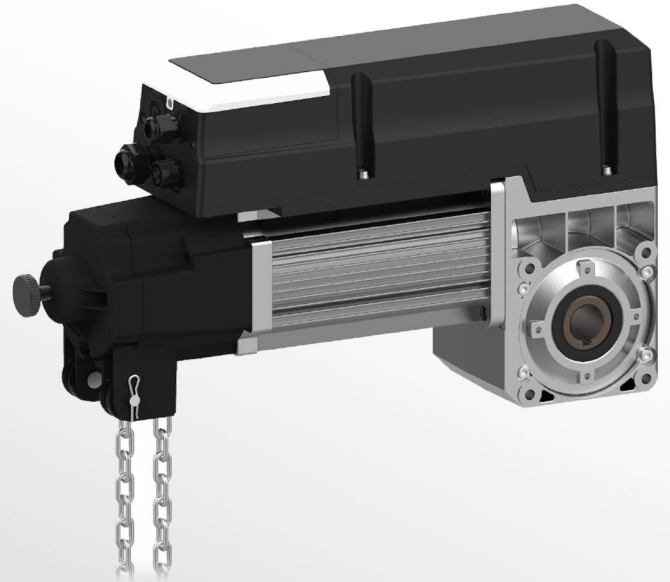

.SOFT START & SOFT STOP



.AC DRIVE



.OPENING & CLOSING SPEED
ADJUSTABLE

Application

- FACTORY/ WAREHOUSE INDUSTRIAL DOORS
- LOGISTICS CENTER DOORS
- COMMERCIAL ENTRANCE DOORS
- ALUMINUM GLASS DOORS

Door Type Supported

- SANDWICH INSULATED GARAGE/INDUSTRIAL DOORS
- ALU PANORAMA OR COMMERCIAL INDUSTRIAL DOORS



Door Size Supported

- UPTO 40 M2 DOOR SIZE SUPPORTED
- UPTO 520 KGS DOOR WEIGHT SUPPORTED
- UPTO 9.5M DOOR HIGH SUPPORTED

PARAMETER . BEAR 120

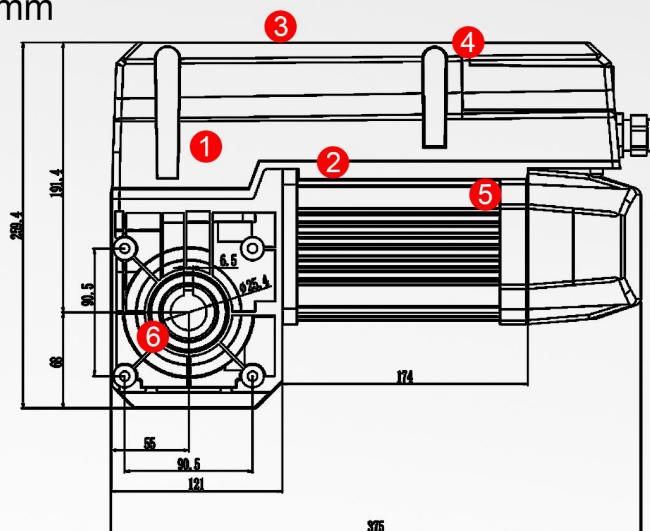
Maximum output torque	140Nm	
Rated output torque	120Nm	
Input voltage	110/220(1+10%)V 60Hz/50Hz 380V-420V	
Control system	24V AC	
Motor power	850W	① Gearbox
Static holding torque	400Nm	② motor
Max. output speed	18rpm-24rpm	③ Casing
Max. closing speed	10rpm-18rpm	④ Flip
Operation limit turns (limit travel)	15 turns of output shaft <i>(max. 5.0m lifting height recommend)</i>	⑤ Rear trim cover
Sleeve shaft diameter (standard)	φ25.4mm/φ31.75mm	⑥ Front clutch
Keyway size	6.3mm	
Thermal protection temperature	105°C	
Continuous sound pressure level	<70dB	
Max. cycles per hour	20	
IP protection class	IP54	
Temperature range	- 20°C /+ 60°C	
Standard kit	Drive motor&wired control box	
Chain hoist module	Including	
Optional edge sensors kit	Optional	



Standard sectional doors with cylindrical cable drum			
	Door size(max.)	40m²	Door weight(max.) 520kg
Vertical lift sectional doors with conical cable drum			
	Door size(max.)	36m²	Door weight(max.) 468kg
High lift sectional doors with cylindrical-conical cable drum			
	Door size(max.)	40m²	Door weight(max.) 520kg