



SAFETY BRAKE



Tel: +86-572-6267 780/6266 596 Fax: +86-572-6267 892 E-mail: dp@China-develop.com
Website: www.china-develop.com

SAFETY BRAKE

Safety brake is a safety device that usually used in garage door installation. The device triggers when the door drops fast under the failure of motor. It will ensure that people or vehicles will not be hit by the dropping door.

Our factory produces safety brake in 18mm, 30mm, 40mm and 50mm, also customization is acceptable, to satisfy the diverse market demand.

Our safety brake are tested and certified according to the strictest guidelines. It can be assured that all of devices are of the highest Germany Quality with the TUV certified.



PRODUCT DISPLAY

■ RSB-1-18E

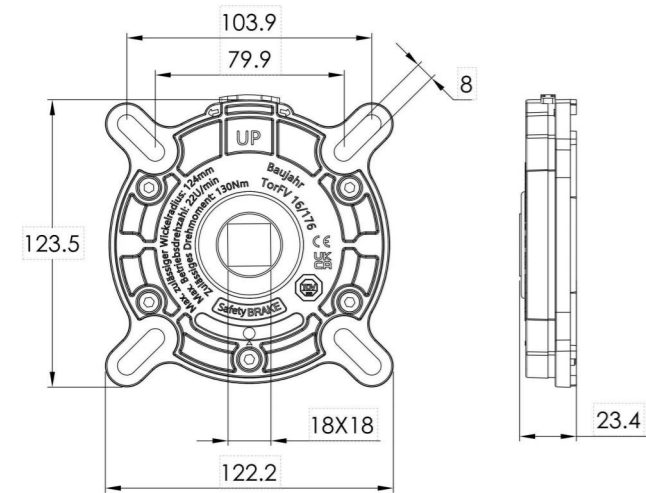

TECHNICAL DATA OF SAFETY BRAKE

SERIES	MAX.SPEED	RUN TORQUE (STATIC)	MAX. WINGING RADIUS (OUTSIDE)	INSTANT MAX.TOTRQUE	BOLT TORQUE
	(r/min)	(N.m)	(mm)	(N.M)	(N.M)
RSB-1-18E	22	130	124	150	9



PRODUCT DISPLAY

■ RSB-1-18/A

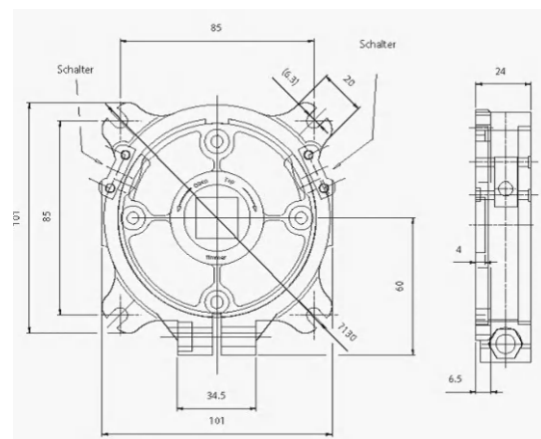

PRODUCT DISPLAY

■ RSB-1-18/F

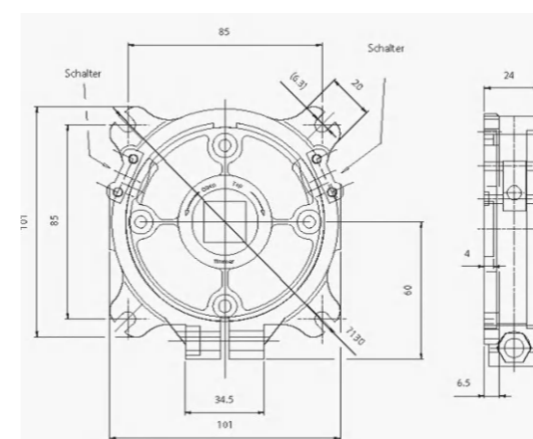

PRODUCT DISPLAY

■ RSB-1-18/N

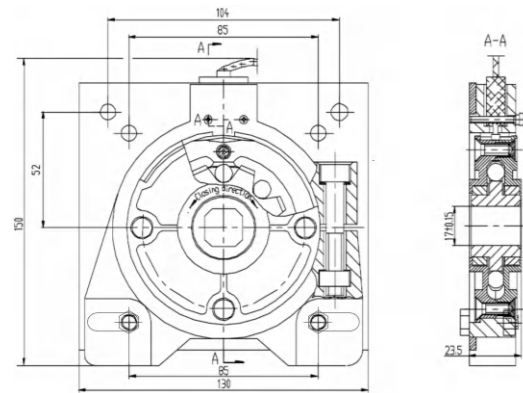

TECHNICAL DATA OF SAFETY BRAKE

SERIES	MAX.SPEED (r/min)	RUN TORQUE (STATIC) (N.m)	MAX. WINGING RADIUS (OUTSIDE) (mm)	INSTANT MAX.TOTRQUE (N.M)	BOLT TORQUE (N.M)
RSB-1-18/A	22	130	124	520	10
RSB-1-18/F	22	96	124	198	7
RSB-1-18/N	22	130	124	520	10



BRAKE BRACKET

▼ SHAFT+DISCS CAN BE CUSTOMIZED

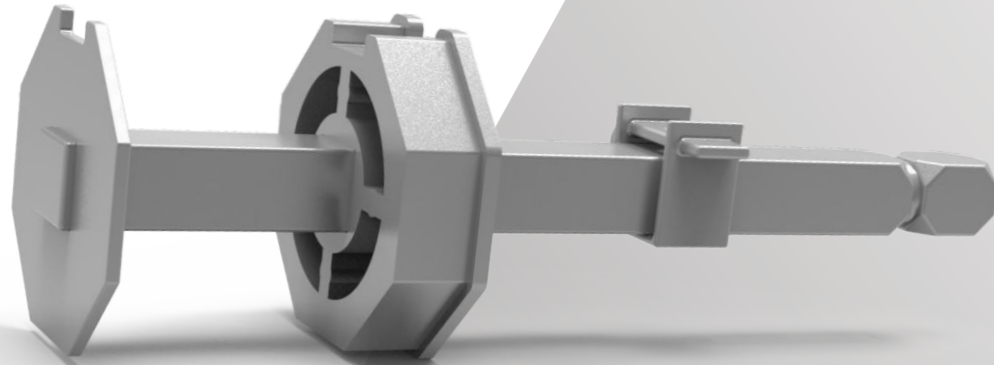

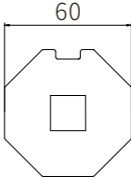
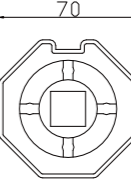
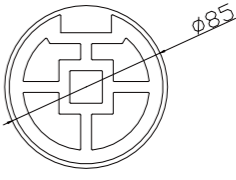
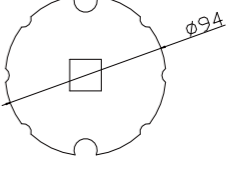
NAME	PICTURE
16017-18/060	
16017-18/070	
16017-18/R85	
16017-18/R94	

PRODUCT DISPLAY

■ RSB-1-30

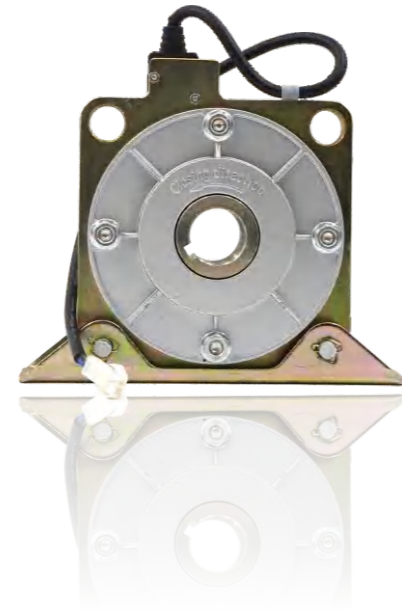
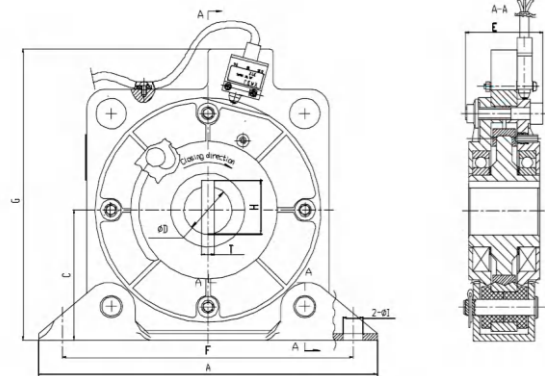

PRODUCT DISPLAY

■ RSB-1-40

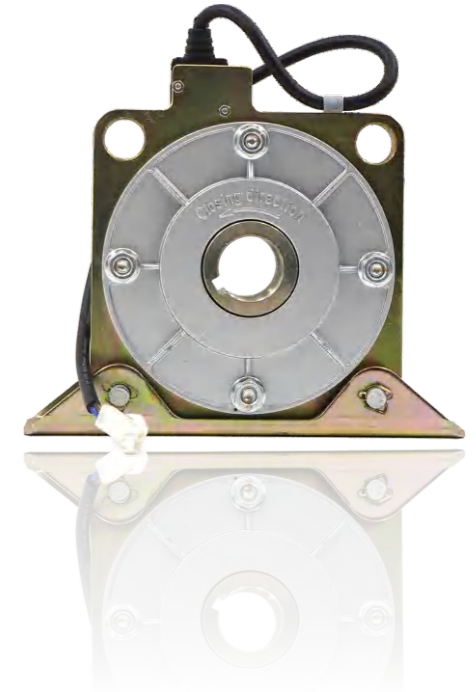
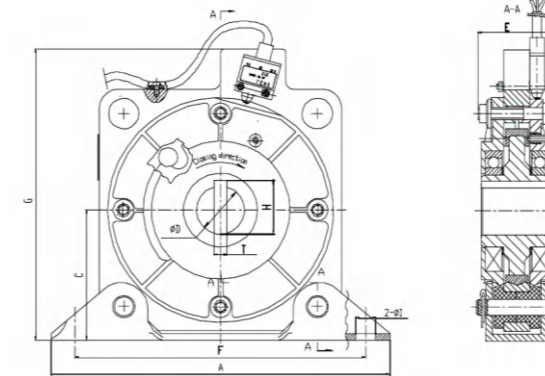

PRODUCT DISPLAY

■ RSB-1-50

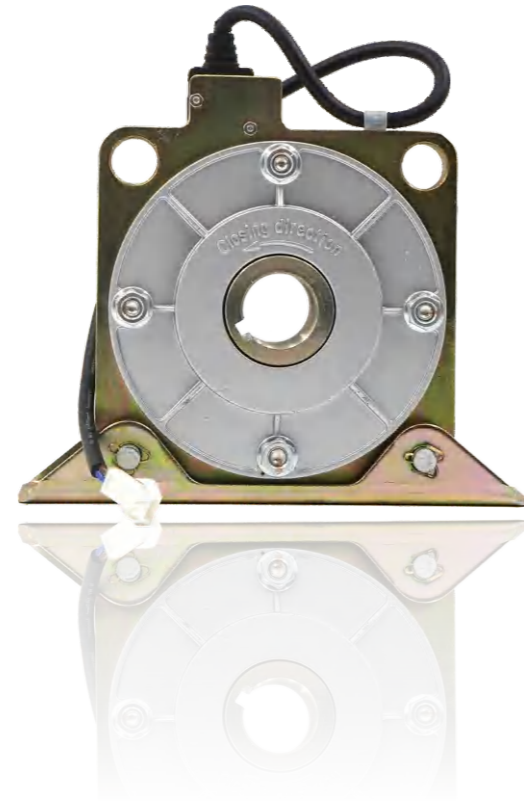
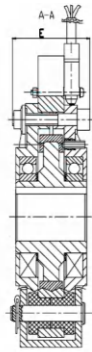
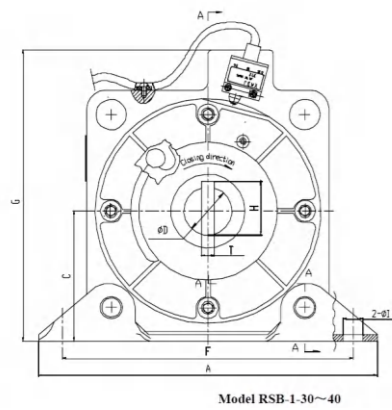

TECHNICAL DATA OF SAFETY BRAKE

SERIES	MAX.SPEED (r/min)	RUN TORQUE (STATIC) (N.m)	MAX. WINGING RADIUS (OUTSIDE) (mm)	INSTANT MAX.TOTRQUE (N.M)	BOLT TORQUE (N.M)
RSB-1-30	22	368	145	1444	15
RSB-1-40	22	650	189	2058	28
RSB-1-50	20	1031	160	3509	35



BRAKE BRACKET

▼ SHAFT+DISCS CAN BE CUSTOMIZED

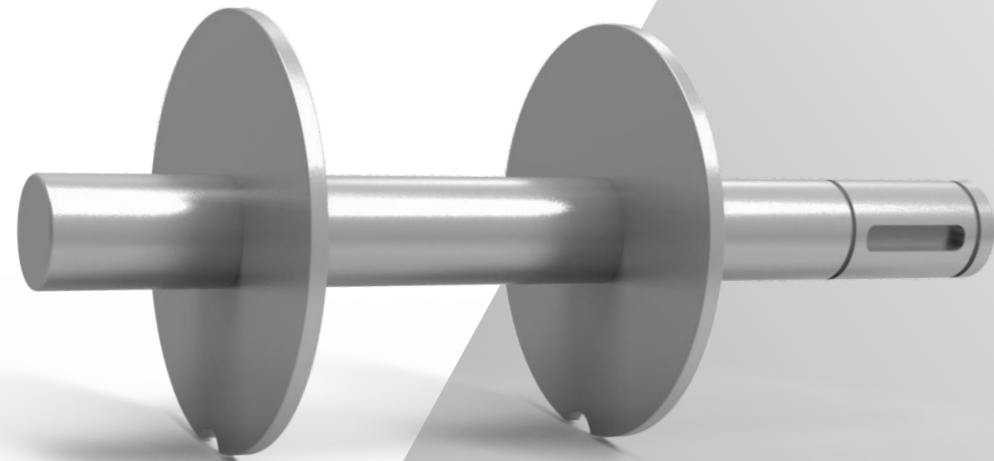

NAME	PICTURE
16017-30/R94	A technical drawing of a brake bracket, showing a circular cross-section with a central hole. The drawing includes two dimension lines: one indicating an inner diameter of $\phi 30$ and another indicating an outer diameter of $\phi 94$.
16017-40/R97	A technical drawing of a brake bracket, showing a circular cross-section with a central hole. The drawing includes two dimension lines: one indicating an inner diameter of $\phi 40$ and another indicating an outer diameter of $\phi 97$.
16017-50/R159	A technical drawing of a brake bracket, showing a circular cross-section with a central hole. The drawing includes two dimension lines: one indicating an inner diameter of $\phi 50$ and another indicating an outer diameter of $\phi 159$.



SAFETY BRAKE

To be a Creator

We are more than a producer for products,
but a creator for a better life.

We are engaged in the promotion for a comfortable,
safe and efficient life.

See more at: www.china-develop.com

Focus on Quality Continuous innovation

Consistently invest in research and development without distractions, with quality as the belief, from product development, production to application experience, we adhere to the world's leading production standards, dare to create, and ultimately improve the quality of users' life.



See more at: www.china-develop.com